

Home Owner's Manual

 **WARNING** 
RISK OF ELECTRIC SHOCK
DO NOT OPEN

CAUTION: TO REDUCE THE RISK OF ELECTRIC SHOCK, DO NOT REMOVE COVER (OR BACK). NO USER SERVICEABLE PARTS INSIDE. REFER SERVICING TO QUALIFIED SERVICE PERSONNEL.



The lightning flash with arrowhead symbol within an equilateral triangle is intended to alert the user to the presence of uninsulated “dangerous voltage” within the product’s enclosure that may be of sufficient magnitude to constitute a risk of electric shock to persons.



The exclamation point within an equilateral triangle is intended to alert the user to the presence of important operating and maintenance (servicing) instruction in the literature accompanying the appliance.

WARNING: TO REDUCE THE RISK OF FIRE OR SHOCK, DO NOT EXPOSE THIS APPLIANCE TO RAIN OR MOISTURE.

IMPORTANT SAFETY INFORMATION

Read Information—All the safety and operating information should be read before the appliance is operated.

Follow Information—All operating and use information should be followed.

Retain Information—The safety and operating information should be retained for future reference.

Heed Warnings—All warnings on the appliance and in the operating instructions should be heeded.

Wall Mounting—Mounting of this appliance should be done only by an authorized installer.

Ventilation—The appliances should be situated so that their location or position does not interfere with their proper ventilation. These appliances should never be placed near or over a radiator or heat register. These appliances should not be placed in a built-in installation such as a bookcase or cabinet that may impede the flow of air through the ventilation openings.

Non-Use Periods—Appliances that are left unattended and unused for long periods of time should be de-energized.

Power Sources—The appliances should be connected to a power supply only of the type described in the operating instructions or as marked on each appliance. If you are not sure of the type of power supply to your home, consult your authorized ELAN HOME SYSTEMS AV/EC dealer or local power company.

Grounding or Polarization—These audio products must be connected to a grounding-type alternating-current circuit on a dedicated circuit breaker. This is a safety feature. The green safety wire from the A.C. circuit must be connected.



Water and Moisture—To reduce the risk of electric shock or fire, these appliances should not be used near water—for example, near a bathtub, washbowl, kitchen sink, laundry tub, in a wet basement, or near a swimming pool.

Power Cord Protection—A.C.Power supply circuits should be routed by a certified electrician only, in accordance with the NEC standards.

Telephones—Avoid using a telephone (other than a cordless type) during an electrical storm. There may be a remote risk of electrical shock from lightning. Do not use a telephone to report a gas leak if the leak is in the vicinity of the ELAN electronic equipment because of risk of fire or explosion.

Cleaning—Turn off the circuit breaker to this audio product before cleaning. Do not use liquid or aerosol cleaners. Use a damp cloth for cleaning.

Power Lines—An outdoor antenna should be located away from power lines. When installing an outside antenna system, extreme care should be taken to avoid touching power lines or circuits, as contact with them may be fatal.

Outdoor Antenna Grounding—If an outside antenna or cable system is connected to these audio products, be sure the antenna or cable system is grounded so as to provide some protection against voltage surges and built-up static charges. Section 810 of the U.S. National Electrical Code, and Section 54 of the Canadian Electrical Code, provide information with respect to proper grounding of the mast and supporting structure, grounding of the lead-in wire to an antenna discharge unit, size of grounding conductors, location of antenna-discharge unit, connection to grounding electrodes, and requirements for the grounding electrode. See the grounding diagram (right).

Overloading—Do not overload wall outlets and extension cords, as this could result in fire or electric shock.

Object and Liquid Entry—Never insert objects of any kind through the openings of these appliances, as they may touch dangerous voltage points or short-out parts that could result in a fire or electric shock. Care should be taken so that objects do not fall and liquids are not spilled into the appliance through openings in the enclosure.

Servicing—Do not attempt to service these appliances yourself, as opening or removing covers may expose you to dangerous voltage or other hazards. Refer all servicing to qualified service personnel.

Damage Requiring Service—These appliances should be serviced by qualified service personnel when:

- A power supply connection or a plug has been damaged or
- If liquid has been spilled into the appliance or objects have fallen into the appliance or
- The appliance has been exposed to water or moisture or
- The appliance does not appear to operate normally or exhibits a marked change in performance or
- The appliance has been dropped or the enclosure damaged.

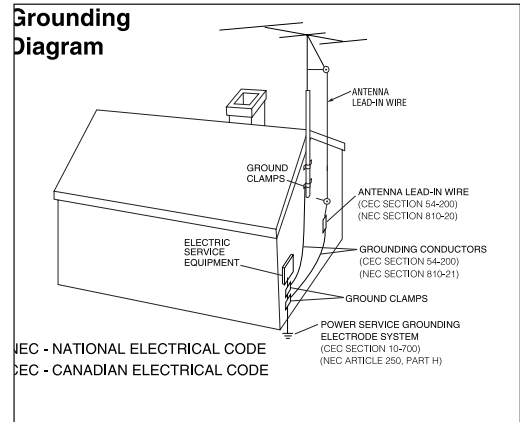

Replacement Parts—When replacement parts are required, be sure the service technician has used replacement parts specified by the manufacturer or that have the same characteristics as the original part. Unauthorized substitutions may result in fire, electric shock, or other hazards.

Safety Check—Upon completion of any service or repairs to this audio product, ask the service technician to perform safety checks to determine that the audio product is in proper operating condition.

Lightning—For added protection for these audio products during an electrical storm, or when they are left unattended and unused for long periods of time, turn off the circuit breaker, and disconnect the antenna or cable system. This will prevent damage to the audio products

IMPORTANT USER INFORMATION

THE AV/EC AV-L2 has been registered with the Federal Communications Commission (FCC) in accordance with Parts 68 of its rules. On the front panel of the Series 5000 Audio Distribution Amplifier is a label that contains, among other information, the FCC registration number and ringer equivalence number (REN) for this equipment. If requested, this number must be given to the telephone company.

FCC Registration Number: 5J7USA-30852-MA-T
Ringer Equivalence Number (REN): 1.1F

The REN is useful in determining the quantity of devices you may connect to your telephone line and still have all those devices ring when your number is called. In most, but not all areas, the sum of all RENs of all devices connected to one line should not exceed five (5.0). To find out the number of devices you may connect to your line, as determined by the REN, contact your local telephone company for the maximum REN for your calling area.

If your telephone equipment causes harm to the telephone network, the telephone company may discontinue your service temporarily. If possible, they will notify you in advance. But, if advance notice isn't practical, you will be notified as soon as possible. You will be notified of your right to file a complaint with the FCC.

Your telephone company may make changes in its facilities, equipment, operations, or procedures that could affect the proper functioning of your equipment. If they do, you will be notified in advance to give you an opportunity to maintain uninterrupted telephone service. If you experience trouble with this telephone equipment, please contact **ELAN HOME SYSTEMS TECHNICAL SUPPORT** at **1-859-269-7760** for information on obtaining service or repairs. The telephone company may ask that you disconnect this equipment from the network until the problem has been corrected or until you are sure the equipment is not malfunctioning.

If the telephone features are not functioning or are malfunctioning, switch the circuit breaker connected to the ELAN System **off**. This will directly connect the telephone line with all the telephones connected to the package. Contact your dealer for repairs.

This equipment may not be used on coin service provided by the telephone company. Connection of party lines is subject to state tariffs. (Contact your state public utility commission for information).

This device complies with Part 15 of the FCC Rules. Operation is subject to the following conditions: (1) This device may not cause harmful interference and (2) this device must accept any interference received, including interference that may cause undesired operation.

Notice

The Canadian Department of Communications label identifies certified equipment. This certification means that the equipment meets certain telecommunications network protective, operational, and safety requirements. The Department does not guarantee the equipment will operate to the user's satisfaction.

Before installing this equipment, users should ensure that it is permissible to be connected to the facilities of the local telecommunications company. The equipment must also be installed using an acceptable method of connection. In some cases, the company's inside wiring associated with a single line individual service may be extended by means of a certified connector assembly (telephone extension cord). The customer should be aware that compliance with the above conditions may not prevent degradation of service in some situations.

The Load Number (LN) determines the number of devices you may connect to your line. The LN sum of all devices connected to one line shall not exceed 100.

Repairs to certified equipment can only be made by the manufacturer.

This digital apparatus does not exceed the Class B limits for radio noise emissions from digital apparatus set out in the Radio Interference Regulations of the Canadian Department of Communications.

Contact **ELAN HOME SYSTEMS TECHNICAL SUPPORT** at **1-859-269-7760** for repairs to certified equipment. For "on-site" technical support, call 1-800-622-3526.

Table of Contents

Safety and User Information	I-III
Introduction	1
The Features	
Whole-House Music Distribution	2
Integrated Telephone, Intercom & Door Chime	3,4
Telephone Usage Tips	4-6
Connecting Your Stereo System	7
Accessories & Options	8,9
Warranty	10
Quick Reference Guide	Back Cover

Introduction

Your home has been pre-wired for the ELAN AV/EC Wire Management Center — a structured wiring network that will allow you to do more than you ever imagined with the very same entertainment & communication devices you have been using all your life. It also provides you with an upgrade path for many future technologies for the home. The AV-L2 is the heart of that system.

With the AV-L2, your stereo receiver, CD player, tape deck, VCR and DVD player become whole-house music sources that can be listened to and controlled from just about anywhere in the house.

With the AV-L2 your standard touch-tone telephones—even the cordless ones—become an integrated paging and intercom system that lets you communicate with anyone anywhere in the house.

Optional enhancements to the system, such as the AV/EC AV-U2, U3, U4 and U5 Video Distribution Panels, Door Stations, Closed Circuit TV Cameras, Digital Modulators, Infrared Control and Multi-Channel Power Amplifiers allow you to:

- view clean, clear cable TV, satellite, DVD and VCR signals at up to sixteen television locations.
- have pleasing, digitally-sampled DOOR CHIMES broadcast over the speakers throughout your home whenever there's a visitor at the door.
- speak to visitors at your front door or gate from any telephone in the home, and even use the phone to 'buzz' them in.*
- use your TVs as security monitors, allowing you to view entranceways, play areas and swimming pools simply by selecting a channel on your TV.
- control all your source components from different rooms via handheld remote controls.
- add a virtually unlimited number of AV/EC rooms with music, paging and door chime.

* Door latch activation requires a third party electronic latch be installed. Consult your authorized ELAN Home Systems AV/EC installation specialist for details.

The Features

Whole-House Music Distribution

The premise is quite simple—The AV-L2 lets you listen to your existing stereo components in any room of the home where speakers have been installed. There's nothing new to learn—you operate your stereo system exactly the same way you always have. The only difference is that now when you go to your stereo receiver and select the CD player, you'll be able to listen to it in the Kitchen, Master Bedroom, Garage, etc., as well as in your main media room. The only other thing you need to concern yourself with is how loud you want to listen to it in any given location—and stylish, in-wall volume controls in each room provide the means. Regardless of how loud the music may be in your media room (very soft or crankin'!), every other room in the home always maintains its own independent volume.

Where's that sound coming from . . . ?

Architecturally discreet, high-quality speakers can be placed in the walls or ceilings of any room. Whether it's just background music needed in a bath-room or garage, or bass-thumping sounds in the family room or out on the deck—ELAN Select™ and Signature™ Series speakers provide clean, rich sound to any location. The low-profile speaker frames and grills can even be painted or wallpapered so that they 'disappear' into the wall or ceiling.

Total Control

The AV-L2 has a built-in, powered Infrared Repeater System. Options such as the IRC2000 In-Wall IR Receiver allow you to control all your stereo components from whatever room you are in. Installing an MS3000 In-Wall Music Switch will allow you mute the music throughout the home without having to go to the main system. Up to four IRC2000 IR receivers and four MS3000 Music Switches can be installed.

Integrated Telephone, Intercom and Door Chime Features

Question #1: *What electronic communications device resides in virtually every room in the house?*

Question #2: *What electronic communications device have you been using since before you can remember?*

The answer to both—THE TELEPHONE!

That's the premise behind the AV-L2's intuitive, user-friendly, integrated telephone system. The AV-L2 lets you use standard corded and cordless touch-tone telephones for a myriad of whole-house communication features, such as . . .

Whole-House Paging (#,P)

Unlike traditional intercom systems where you have to get up from the comfort of your arm chair to talk into a small box on the wall, the AV-L2 allows you to simply pick up the phone on the table next to you and page throughout the entire home. Your page is broadcast over the same speakers you've had installed around the house for music. Should music be playing when a page is initiated, the music will mute for the duration of the page and then resume. With most cordless phones, this feature could just as easily be initiated from your back yard or next door neighbor's house.

How easy is it to initiate a page? Simply press #,P (7).

Phone-to-Phone Intercom (#,P,0)

By following a PAGE (#,P) with a zero, you instantly mute the page audio coming over the speakers (the music will resume if it had been playing) and connect the phone you are on to every other phone in the house. Whoever you paged simply picks up any extension and that's it—phone-to-phone intercom!

Door Station Communications (#,D)

(requires DS1500 or DS1550 Electronic Door Speaker Assembly)

You're in the kitchen. Your favorite radio station is playing over the kitchen's ceiling speakers. The music mutes just long enough for you to hear the ELAN Door Chime broadcast, then resumes. You pick up the phone on the wall in front of you, press #,D (3), and speak to the visitor at the front door. Then . . .

Door Latch Activation (#,D,0)

. . . if you like them well enough, you simply press '0' and let them in.*

Caller On-Hold (#,H)

Want to hang up the phone and take the call in another room? Just press #,H (4). When you pick up any other phone in the house the caller will automatically be there.

Music Mute (#,M)

Pressing #,M (6) will mute the music throughout the entire home. Hang up the phone (or flash-hook) and the music will resume.

Telemute

This is an automatic feature that mutes the music throughout the house when the telephone rings. The music resumes when the phone is answered.

Page & Door Chime Override

The AV/EC AV-L2 uses mono and/or stereo volume controls with a patented override feature. This allows for page and door chime audio to be heard in every room even if the volume control in that room happens to be turned all the way down.



Telephone Usage Tips

The System Dial Tone

The AV-L2 has been registered with the Federal Communications Commission (FCC) and complies with all required FCC regulations (see Page iii). In accordance with these regulations, the AV-L2 has a distinct system dial tone that you should familiarize yourself with. The system dial tone is also an indicator that power is being supplied to the AV-L2.

Placing Calls

To place a call, pick up the phone and dial—that's it! You will automatically be connected to your local telephone service.

* Door latch activation requires a third party electronic latch be installed.

The #,9 System Bypass

When calling your credit card company or your bank, you are sometimes prompted by the automated attendant to “please enter your account number followed by the pound sign.” In these instances it will be necessary to press #,9 either before dialing out or after the connection has been made. Pressing #,9 bypasses the AV-L2 and allows your credit card company or bank to respond to the use of the pound key.

If you are using a telephone company answering service, use the #,9 System Bypass feature to access the special “stutter” dial tone used by the phone company to indicate that you have messages.

Hanging up the phone (or doing a flash-hook) will automatically reinstate the system.

Caller ID

Unfortunately, there is no FCC-approved standard for sending caller ID information down the line to your caller ID box or phone. Different telephone service providers deliver this data in one of two ways:

1. Caller ID data is sent before the first ring, or as is more often the case,
2. Caller ID data is sent after the first ring and during the “quiet time” between subsequent rings.

The AV-L2 is compatible with the later (#2). Please consult your local telephone company and/or your authorized ELAN Home Systems AV/EC installer before specifying caller ID devices for your home.

Fax Machines, Modems and Answering Machines

Although many of these devices work just fine with the AV-L2, to avoid any potential compatibility issues we suggest that these devices be wired “in front” of the AV-L2 or, in the case of fax machines and modems, be placed on a dedicated phone line. If possible, decide where these devices are to go ahead of time, and have your installer wire those jacks accordingly.

Speed Dialing

If your telephones have programmable Speed Dial numbers, entering the AV-L2’s telephone commands into them can make the already easy-to-use features even easier!

Paging Tips

General Information:

- Pick up any phone and press #,P (7). Your page will be heard over all the speakers in the home. If there was music playing when you initiated the page, the music will mute for the duration of the page and resume when you hang up the phone or press zero.
- Following a #,P command with a zero will mute the page audio coming over the speakers and connect you directly to every other phone in the house for phone-to-phone intercom. The zero can be initiated by the person who initiated the page or by a person picking up another extension.

Paging With A Caller On The Line

- Pressing #,P will automatically place the caller on hold while you page. Pressing any digit (except zero) will bring the caller back on line. If you hang up the phone after initiating a page, the person you paged need only pick up any phone in the house and the caller will be there.
- If you followed a #,P command with a zero to initiate the phone-to-phone intercom mode, press any digit or flash-hook to get the caller back.

Incoming Calls While in Page or Intercom Mode:

- If there is an incoming call while you are in page mode, you will hear the first ring, and every subsequent fourth ring, over the speakers in the house. To access the caller, press any digit except zero, or flash-hook.
- If there is an incoming call while you are in phone-to-phone intercom mode, you will hear the first ring, and every subsequent fourth ring, over the telephone handset. To access the caller, press any digit or flash-hook.

Door Speaker Communications

- Press #,D (3) to initiate 2-way door speaker communications (the music will not mute).
- Following a #,D command with a zero will activate the door latch mechanism. The door latch will remain activated for as long as you hold the zero.*
- If there is an incoming call while you are communicating to the door station, you will hear the first ring, and every subsequent fourth ring, over the telephone handset. To access the caller, press any digit or flash-hook. To re-access the door station you must press #,D again.

* Door latch activation requires a third party electronic latch be installed. Consult your authorized ELAN Home Systems AV/EC installation specialist for details.

Connecting Your Stereo System to the AV-L2

All system connections and adjustments have probably been made for you by your authorized ELAN Home Systems AV/EC installer. You may, however, have just moved into a home that has been previously wired for the AV-L2 and need to connect your stereo system to the AV-L2. Here's how . . .

Find the MUSIC INPUT WALL PLATE. This is a single-gang, Decora®-style wall plate that sends the audio from your stereo to the AV-L2 for whole-house distribution. The MUSIC INPUT WALL PLATE will probably be located in one of the main rooms of the home—Family Room, Media Room, etc. This is where you will need to locate your stereo system.

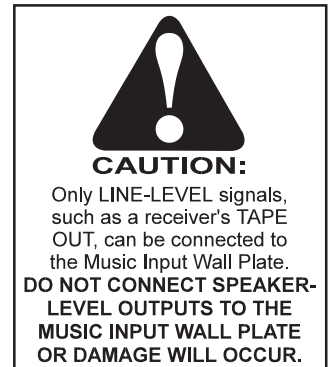

Using a standard stereo RCA interconnect cable, plug one end into the MUSIC INPUT WALL PLATE. The top jack is for the Right channel; the bottom jack is for the Left channel.

Connect the other end of the stereo interconnect cable to the TAPE OUT/RECORD OUT Left and Right jacks on your stereo receiver or pre-amp.

That's all there is to it. Now, whatever source (Tuner, CD, DVD, Tape, etc.) you select at the front of your receiver will be sent to the AV-L2, then amplified and distributed throughout the rest of the home.

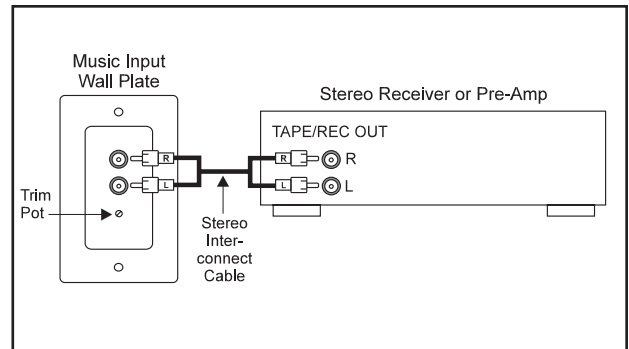

Adjusting the Whole-House Music Distribution Level

Located beneath the Left and Right RCA jacks on the MUSIC INPUT WALL PLATE is a screwdriver-adjustable trim pot. This is used to adjust the audio level that is being sent from your stereo to the AV-L2. The trim pot comes factory set at halfway, and this setting should be adequate in most cases.

Should you feel that you are not getting enough volume level throughout the house, use a small flat-head screwdriver to turn the trim pot up (clockwise). Do this slowly and in small increments. Check the level in a few rooms between increments. If you hear any distortion, turn the trim pot back down immediately.

Distortion should never be present even if the volume controls are turned all the way up. If the level throughout the house is too loud, turn the trim pot in a counterclockwise direction until it is satisfactory.

Accessories and Options

AV/EC Video Distribution Panels

These panels mount into the upper portion of the same box that your AV-L2 is in and provide you with multiple video distribution options:

AV-U2

Distributes coaxial video to four TV locations.

AV-U3

Distributes amplified Cable TV signals to 8 TV locations.

AV-U4

Distributes amplified Off-Air/Satellite/VCR signals to 8 TV locations.

AV-U5

Distributes amplified Cable TV signals and amplified Off-Air/Satellite/VCR signals to 16 TV locations.

Each of the above also includes a Category 5-rated Telephone Punchdown Block that serves as the hub for all your Telephone, Modem, Fax and Ethernet connections.

Select™ and Signature™ Series In-Wall, Ceiling and Outdoor speakers provide a full range of options for background, casual and serious listening areas in and around the home.

DS1500 and DS1550 Door Stations allow you to use your telephones to speak with a visitor at your door, and even let them in by activating a door latch control. **

Accessories and Options continued next page....

**DS1550 only.

Closed Circuit TV Cameras (CAM 4010 or CAM4200 package) let you view visitors at the front door as well as monitor driveways, play areas, pools and more from any TV.

Matching, high-quality **Brass, Chrome and Ivory faceplates for the Door Stations and the Closed Circuit TV Cameras** make for an extremely classy entranceway to your home.

IRC2000 In-Wall, Decora®-style Infrared Receivers allow you to control your source components via handheld remote controls from virtually anywhere in the home.

Z-Series Power Amplifiers give you the capability of adding on even more rooms of high-power, high-quality music, paging and door chime.

For more information about ELAN Home Systems comprehensive home products and systems, contact your authorized installer, or visit the ELAN website at: www.elanhomesystems.com, or call 1-859-269-7760.

Limited Warranty

ELAN HOME SYSTEMS, L.L.C. (“ELAN”) warrants equipment manufactured by it to be free from defects in materials and workmanship for two (2) years from the date of purchase, with the exception of speakers and volume controls, which have a ten (10) year warranty. If within the applicable warranty period above purchaser discovers such item was not as warranted above and promptly notifies ELAN writing, ELAN shall repair or replace the items at the company’s option. This warranty shall not apply (a) to equipment not manufactured by ELAN, (b) to equipment which shall have been installed by other than an authorized ELAN installer, (c) to installed equipment which is not installed to ELAN’s specifications, (d) to equipment which shall have been repaired or altered by others than ELAN, (e) to equipment which shall have been subjected to negligence, accident, or damage by circumstances beyond ELAN’s control, including, but not limited to, lightning, flood, electrical surge, tornado, earthquake, or any other catastrophic events beyond ELAN’s control, or to improper operation, maintenance or storage, or to other than normal use of service. With respect to equipment sold by, but not manufactured by ELAN, the warranty obligations of ELAN shall in all respects conform and be limited to the warranty actually extended to ELAN by its supplier. The foregoing warranties do not cover reimbursement for labor, transportation, removal, installation, or other expenses which may be incurred in connection with repair or replacement.

Except as may be expressly provided and authorized in writing by ELAN, ELAN shall not be subject to any other obligations or liabilities whatsoever with respect to equipment manufactured by ELAN or services rendered by ELAN.

THE FOREGOING WARRANTIES ARE EXCLUSIVE AND IN LIEU OF ALL OTHER EXPRESSED AND IMPLIED WARRANTIES EXCEPT WARRANTIES OF TITLE, INCLUDING BUT NOT LIMITED TO IMPLIED WARRANTIES OF MERCHANTABILITY AND FITNESS FOR A PARTICULAR PURPOSE.



Telephone Features Quick Reference Guide

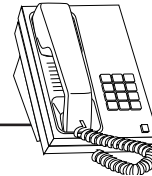

PAGE	# , ^{PAGE} 7	<p>“P” for <i>PAGE</i>.</p> <p>Speak into the phone receiver and your voice will be heard throughout the house over the speakers. Pressing # automatically places a caller on hold; to return to the caller after the page, press # again.</p>
PHONE-TO-PHONE INTERCOM	# , ^{PAGE} 7 , ^{OPER} 0	This allows you to talk with someone at another phone in the house after a page, without the conversation being heard over the speakers.
HOLD	# , ^{OPER} 4	<p>“H” for <i>HOLD</i>.</p> <p>Allows you to place caller on hold, hang up, and take the call on another phone in the house.</p>
DOOR SPEAKER	# , ^{DEF} 3	<p>“D” for <i>DOOR</i>.</p> <p>Allows you to use a telephone to speak with a visitor at the door.</p>
DOOR LATCH (OPTIONAL)	# , ^{DEF} 3 , ^{OPER} 0	Activates the door latch relay. The relay operates as long as you hold the ^{OPER} 0 .
SYSTEM	# , ^{WANT} 9	The System Bypass allows you to use outside phone services that require use of the # key.
MUSIC MUTE	# , ^{MUSIC} 6	This command allows you to mute the music coming through your speakers for the duration of an incoming or outgoing call.

Note: If you have a caller on the line and you activate any of the features, the caller is automatically placed on hold.

Off Hook Alert - If phone is left off hook, after two minutes a “beep” is heard over all the speakers.

Telemute - Music mutes for the duration of the telephone ring.

For On-Site Technical Support:
1.800.622.3526

ELAN HOME SYSTEMS • 2428 Palumbo Drive • Lexington, KY 40391

voice 859.269.7760 • fax 859.269.7972 • internet www.elanhomesystems.com • email elan@elanhomesystems.com